

LOGICA 07

Numerically controlled pad printing centre for multicolour printing, on medium and large sized objects

Up to 6 movement axis easily programming

**5 colours dia. 250 mm
6 colours dia. 195 mm
7 colours dia. 160 mm
8 colours dia. 130 mm**

Fully electrical operation

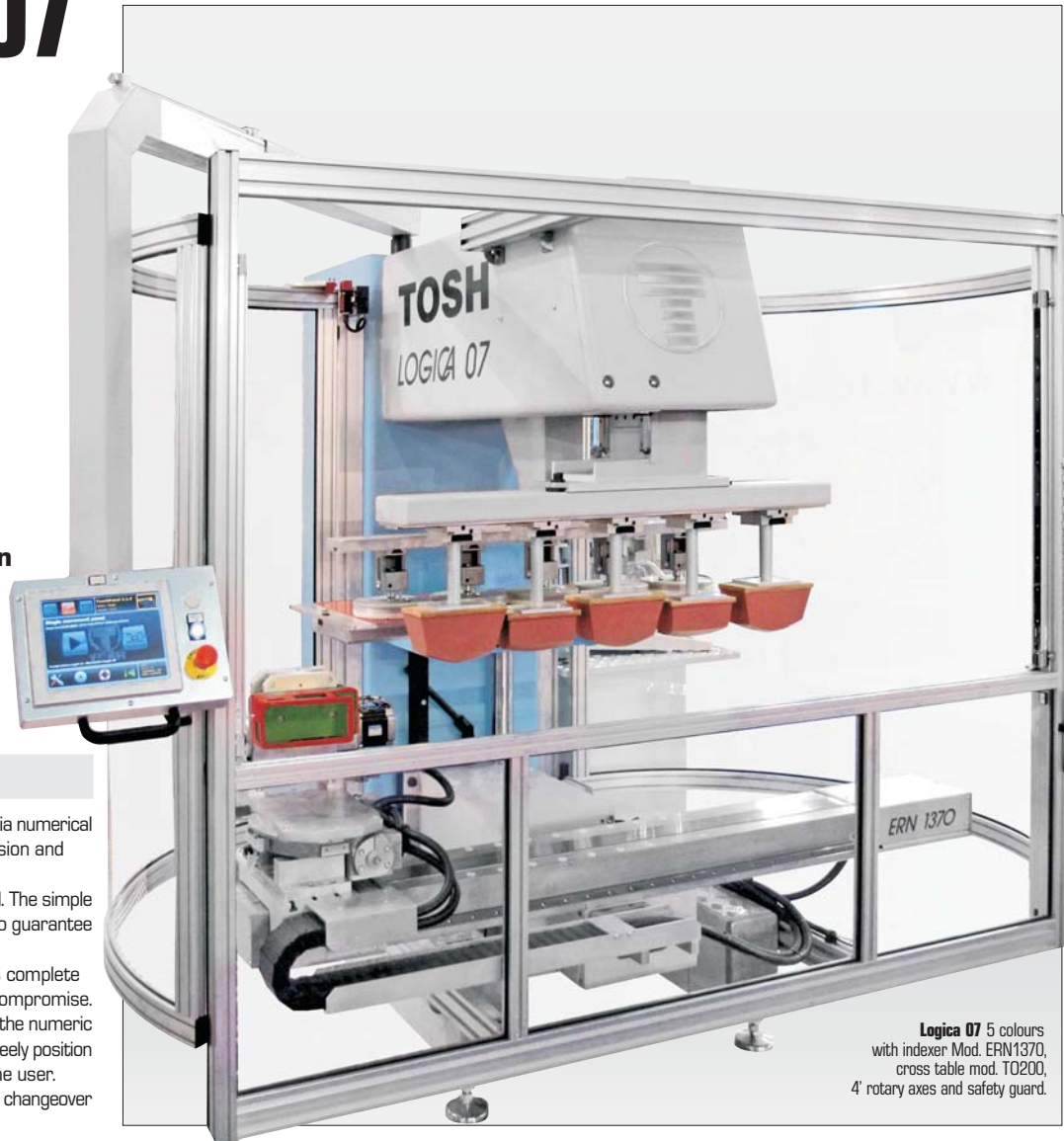

Logica 07 5 colours with indexer Mod. ERN1370, cross table mod. TO200, 4' rotary axes and safety guard.

CHARACTERISTICS

- All the mechanical movements are motorized via numerical control and lead screw, guarantee high precision and smooth working.
- Manufactured from light alloy and special steel. The simple and robust construction was also conceived to guarantee a long life of working without maintenance.
- The computerized numerical control ensures complete flexibility of operation and simplicity without compromise.
- Setting up adjustments can be carried out via the numeric keyboard with alphanumeric display. Ability to freely position the keyboard, where most comfortable for the user.
- Memory of all different work programs for easy changeover set up.
- Automatic colours registering on x y r axes, for immediate start-up (optional).
- Ability to print under the printing plate, allowing decoration in every position on the large sized objects.
- Ability to print on different surface levels of the same object, adjusting easily the stroke through the keyboard.
- Low power consumption, economical since compressed air is not required. It's exclusive electric operation presents a considerable advantage compared to an equivalent pneumatic machine, a saving of more than 5000 kw in a year can be achieved assuming one working shift per day.
- Eco-friendly. Due to its available hermetic ink system preventing solvent evaporation.
- Fully interchangeability between the two systems open and hermetic.
- Changeover time reduced to a few minutes, thanks to the considerations given in the design concept to apply ergonomic principles to the system.
- Exclusive doctoring speeds control system directly through the keyboard.
- Ergonomic design to easy access all mechanical parts.
- Accurate movement of the support slide-table with adjustable height.

TECHNICAL DATA

- Operation: **electric with numerical control**
- Printing force: **11000 N**
- Maximum printing speed: **adjustable up to 1200 c/h (*)**
- Number of colours: **1 - 2 - 3 - 4 - 5 - 6 - 7 - 8**
- Maximum dia. ink cup: **250 mm**
- Standard ink cup sizes: **5 colours dia. 250 mm
6 colours dia. 195 mm
7 colours dia. 160 mm
8 colours dia. 130 mm
or mixed**
- X axes pads register: **+/- 40 mm**
- Vertical stroke: **160 mm**
- Maximum pad height: **270 mm**
- AC supply: **380 V - triple phase - 50/60 Hz**
- Average consumption and weight (basic model): **1,3 KW - about 1500 Kg**

STANDARD PACKAGES

To make the choice easier, Tosh proposes a series of standard packages, between the machine and the conveying systems, that suits your specific application.

Among the suggested and more popular, there are:

- **Cross Table** in different dimensions
- Numerically controlled **indexers** with programmable and adjustable pitch and **automatic pad cleaning**
- Fully electric **Oval flat conveyors**
- Electromechanical numerically controlled **rotary tables**
- Fully electric **rectilinear tracked conveyors**
- Fully electric **rectilinear inclined conveyors**
- **Pre-treatment devices** (flame or corona treatment)
- **Drying devices** (air, U.V. and I.R.)
- Modular **pad pre-drying devices**

On the cover a standard package example of:

Logica 07 5 colours with indexer Mod. ERN1370, cross table mod. TO200, 4' rotary axes and safety guard.

SIZE

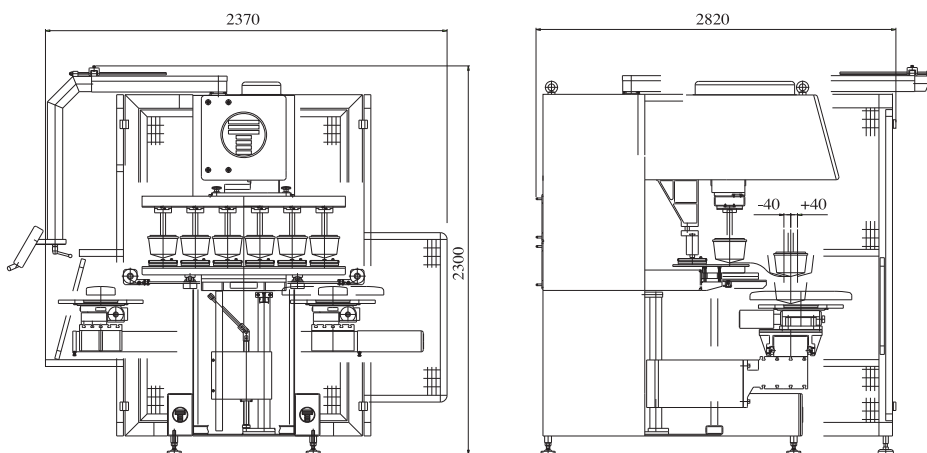

OPTIONAL

Cross tables

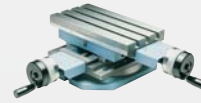

Recommended for applications where there is a single fixture, they allow rapid alignment on more axis of the part to the print.

Indexers



Single fixture linear transfers for multicolour printing on medium and large products.

Oval flat conveyors



Multifixture linear transfers for multicolour printing on small and medium products or used for additional in-line processes

Rotary tables



Recommended for multicolour printing or when high production cadences are required. They can also be used for additional in-line processes.

Rectilinear tracked conveyor



Linear transfer with horizontal rotation axes, available in various dimensions. **RECOMMENDED** in standard configuration, for multi-colours with extra fixtures, for additional functions such as: pre and post treatment, loading and unloading products or when more than one machine is used on line.

Rectilinear inclined conveyor



Linear transfer with inclined working planes is also suitable for use fixtures which, as in the tracked conveyor, run below the printing plane i. e. under the table. Also usable as the oval, flat conveyor, type MEG, but with higher number of fixtures and available in various dimensions. **RECOMMENDED** for multi-colours printing with additional functions to the printing phase, or for multi-stage loading.

Doctoring refresher devices



Ideal for printing large images that don't fit into ink cup size.

BECAUSE OF CONTINUOUS IMPROVEMENT, WE RESERVE THE RIGHT TO CHANGE SPECIFICATION, DESIGN MATERIALS WITHOUT NOTICE.

TOSH®

MACCHINE E SERVIZI
PER LA STAMPA SU OGGETTI



TOSH S.r.l. - Via Lambro 84, I - 20089 Quinto Stampi Rozzano (MI)
Tel. +39 02 57566.1 (10 linee r.a.) - Fax +39 02 89200266
E-mail: info@tosh.it www.tosh.it