

LOGICA MIMICRO N - NS - N90S

Numerically controlled pad printing machine for either one or two colours print.

Fully electrical operation.

Perfect for the approach to the pad printing process in an economic way or for who wants to realize a flexible system for multicolour printing with high mechanical cadence.

CHARACTERISTICS

- All the mechanical movements are motorized via numerical control, guarantee high precision providing complete flexibility of operation and simplicity without compromise.
- Its exclusive electric operation presents a considerable advantage compared to an equivalent pneumatic machine.
- Manufactured from light alloy and special steel.
- Eco-friendly. Due to its available hermetic ink system preventing solvent evaporation.
- Automatic programmable pad cleaning device (optional).
- Independent adjustment of speeds to each of the six strokes, ability to memorize the pad vertical strokes, six diverse temporizations of the most important phases of the printing cycle.
- Changeover time in less than 1 minute, thanks to the consideration given in the design concept to apply the most modern ergonomic principles to the system.
- Due to the mechanical design quality, a guaranteed smooth working function results in an extremely quiet action, thus allowing use in any environment.
- The manufacturing it was also conceived to guarantee a long life of working without maintenance.
- Its modular manufacture allows, with few accessories, the adaptability to numerous production needs.
- Countdown function and memorization up to 16 different work programs for easy set up.
- Ability to print on different surface levels of the same object, adjusting easily the stroke through the keyboard.
- Kit to convert into floor standing model (optional) allows trouble-free movements of the machine and permits the print onto large size objects.
- All adjustment functions can be carried out via the numeric keyboard with alphanumeric display.
- The height of the pad printing head can be independently adjusted from the part holder, based on the operator work position.



Logica MiMicro N

2 colours (dia. 60 mm) with bench support, pad shuttle system Mod. SE 76, cross table Mod. TO 100 and automatic pad cleaning device.

TECHNICAL DATA

- Operation: **electric with numerical control**
- Printing force: **500 N (MiMicro N)**
770 N (MiMicro NS - N90S)
- Maximum printing speed: **adjustable up to 3600 c/h* (MiMicro N)**
adjustable up to 5000 c/h* (MiMicro NS - N90S)
- Number of colours: **1 - 2**
- Vertical stroke: **102 mm**
- Maximum pad height: **90 mm (57 mm with pad shuttle system)**
- Maximum ink cup sizes:

1 col. Mimicro N	60 mm (dia.) 70x145 mm (oval)
1 col Mimicro NS	70 mm (dia.) 70x145 mm (oval)
1 col. Mimicro N90S	90 mm (dia.) 70x145 mm (oval)
2 col. Mimicro N	60 mm (dia.)
2 col. Mimicro NS	70 mm (dia.)
2 col. Mimicro N90S	90 mm (dia.)
- AC supply: **220/240 V - single phase - 50/60 Hz**
- Average consumption and weight (basic model): **about 100 W - about 50 Kg**

(*) The above mentioned printing speed is the max achievable and will reduce when the vertical pad stroke is increased or when delay times have been programmed into the cycle. The maximum printing speed also depends on the parts loading device.

LOGICA MIMICRO N - NS - N90S SERIE LOGICA HIGH SPEED

Logica MiMicro is always supplied with the **bench support (see cover picture).**

Floor stand kit (Fig. 2) is necessary to set up the rotary table TRCN 02 or to allow trouble-free movements of the machine and permits the positioning of large size objects. To use Logica MiMicro on automatic lines, a **kit for installation on automatic line (Fig. 2)** must be used.

This device, if positioned on **trolley bench of connection (Fig. 3)** allows to set up bigger rotary table (i.e. model TRCN 2.5, TRCN 03, TRCN 04).



STANDARD COMBINATIONS

To make the choice easier, TOSH proposes a series of standard combination, between the machine and the conveying system, that suit your specific application. Among the suggested and more popular, there are:

- **Cross tables** in different dimensions
- Electromechanical numerically controlled **rotary tables**
- **Pad shuttle systems**, fully electric operation
- Numerically controlled **indexers** with programmable and adjustable pitch
- **Automatic pad cleaning devices** with programmable operating time
- **Pre-treatment devices** (flame or corona treatment)
- **Drying devices** (air, U.V. and I.R.)
- Modular **pad pre-drying devices**.

On the cover a standard combination example of:

Logica MiMicro N with support bench equipped to print 2 colours with hermetic cups dia. 60 mm, with shuttle system Mod. SE 76, cross table Mod. TO 100 and automatic pad cleaning device.

SIZE BASIC MODEL

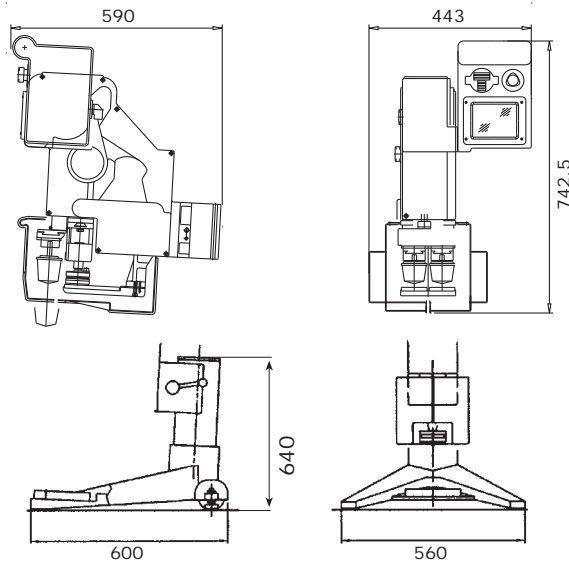

OPTIONAL

Cross tables



To obtain faster and more precise positioning on different axes of a single part holder.

Pad shuttle system



For simultaneous two colours printing on a stopped object; perfect even for printing on cylindrical surfaces.

Indexers



Single fixture linear transfer for multi-colour printing on medium and large products.

Rotary tables



Suitable for multicolour printing or when high production cadence is required. They are utilized even to realize different production line works.

Automatic pad cleaning device



It can perform a pad cleaning cycle with programmable frequency.

Remote keyboard kit

Hub kit

To be fixed in the centre of the rotary table for adding devices as automatic ejection, pre-treatment parts, etc.

Automatic ejection unit

To increase the productivity.

BECAUSE OF CONTINUOUS IMPROVEMENT, WE RESERVE THE RIGHT TO CHANGE SPECIFICATION, DESIGN MATERIALS WITHOUT NOTICE.

TOSH®

MACCHINE E SERVIZI
PER LA STAMPA SU OGGETTI



TOSH S.r.l. - Via Lambro 84, I - 20089 Quinto Stampi Rozzano (MI)
Tel. +39 02 57566.1 (10 linee r.a.) - Fax +39 02 89200266
E-mail: info@tosh.it www.tosh.it